



# JEX

## Stainless Steel Jet Pumps



<b>-SPECIFICATIONS</b>	<b>Page</b>
Features & Applications	100
Typical Exploded View	101
Pump & Motor Specifications	102
Selection Chart / Type key	103
<b>-PERFORMANCE CURVES</b>	
Performance Curve - JEXM 80	200
Performance Curve - JEXM 120	201
Performance Curve - JEXM 150	202
<b>-CONSTRUCTIONS</b>	
Constructions	300
Constructions - Mechanical Seal	301
Constructions – Diagram and Electrical Connections	302
<b>-DIMENSIONS</b>	
Dimensions - Packing and Weight	400
<b>-TECHNICAL DATA</b>	
Technical Data – Motor and Bearings	500
Pump Installation	501

*E.&O.E. All care has been taken to ensure the accuracy of the information and is correct to the best of our knowledge and is given without guarantee. Specifications subject to change without notice.*

Instructions





**Stainless steel jet pumps for the boosting or transfer of water, small scale irrigation, tank & pool emptying, etc. Suitable for installations with suction lift.**

### **Specifications**

- Maximum working pressure : 6 bar
- Maximum liquid temperature: 45°C

### **Materials**

- Pump casing: 304 Stainless Steel
- Impeller: 304 Stainless Steel
- Jet & Diffuser: Noryl
- Shaft : AISI 303 (in contact with liquid)
- Bracket: Aluminium
- Motor Frame: Aluminium
- Mechanical Seal: Carbon/Ceramic/NBR

### **Motor Data**

- TEFC, 2 pole motor
- Insulation class F
- IP55 protection
- 1Ø, 230~240 Volt, 50 Hz
- Permanent split capacitor
- Automatic thermal overload protection

### **Supply**

- 1.8 m cable with 3 pin plug
- Available as pressure system with pressure switch or Presscontrol®

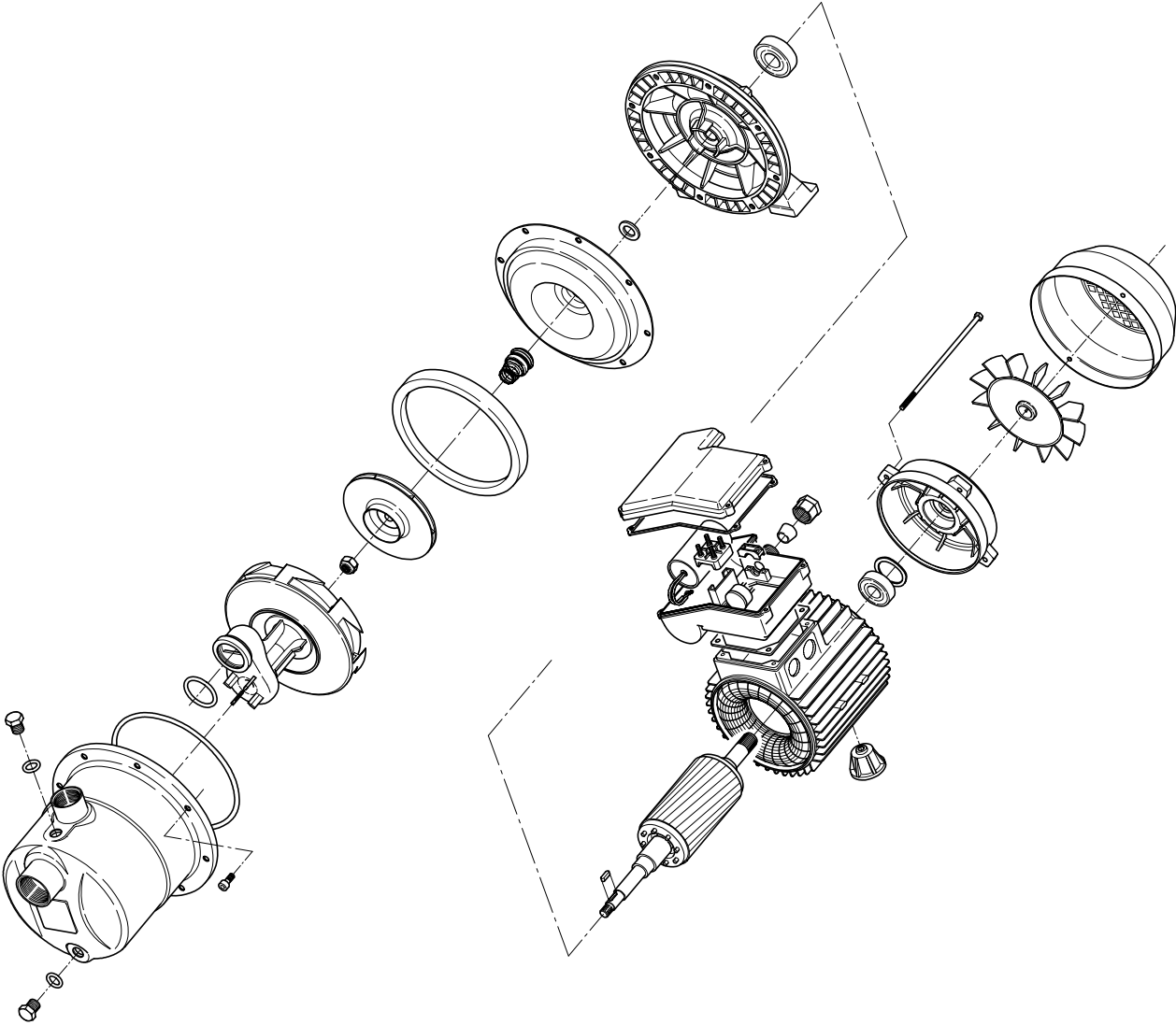

## SPECIFICATIONS - PUMP AND MOTOR

50Hz

V22

PUMP		
Liquid Handled	Type of liquid	Clean water
	Max temperature [°C]	45
Maximum working pressure	[MPa]	0.6
Maximum suction depth	[m]	8
Construction	Impeller	Closed centrifugal type
	Shaft seal type	Mechanical seal
	Bearing	Sealed ball bearing
Pipe Connection	Suction [inch]	G 1¼ UNI ISO 228
	Discharge [inch]	G 1 UNI ISO 228
Material	Casing	AISI 304
	Impeller	AISI 304
	Shaft seal	Ceramic/Carbon/NBR
	Casing cover	AISI 304
	Shaft	AISI 303 (Wet extension)
	Bracket	Aluminium
	Ejector	PPO mod. glass fibre reinforced
	Diffuser	PPO mod. glass fibre reinforced
Applicable standard of test		ISO 9906 – Annex A

MOTOR		
Type		Electric - TEFC
		Single Phase
No. Of Poles		2
Synchronous speed	[min <sup>-1</sup> ]	3000
Insulation Class		F
Protection degree		IP 55
Power rating	[kW]	0.6 ÷ 1.1
	[HP]	0.8 ÷ 1.5
Frequency	[Hz]	50
Voltage	[V]	230 ±10%
Capacitor		Built in
Over load protection		Built in
Casing material		Aluminium
Base material/motor support		Aluminium
Dimensions of cable entry		PG11 - PG13.5 (see dimensions page 400)

## SELECTION CHART

50Hz

V22

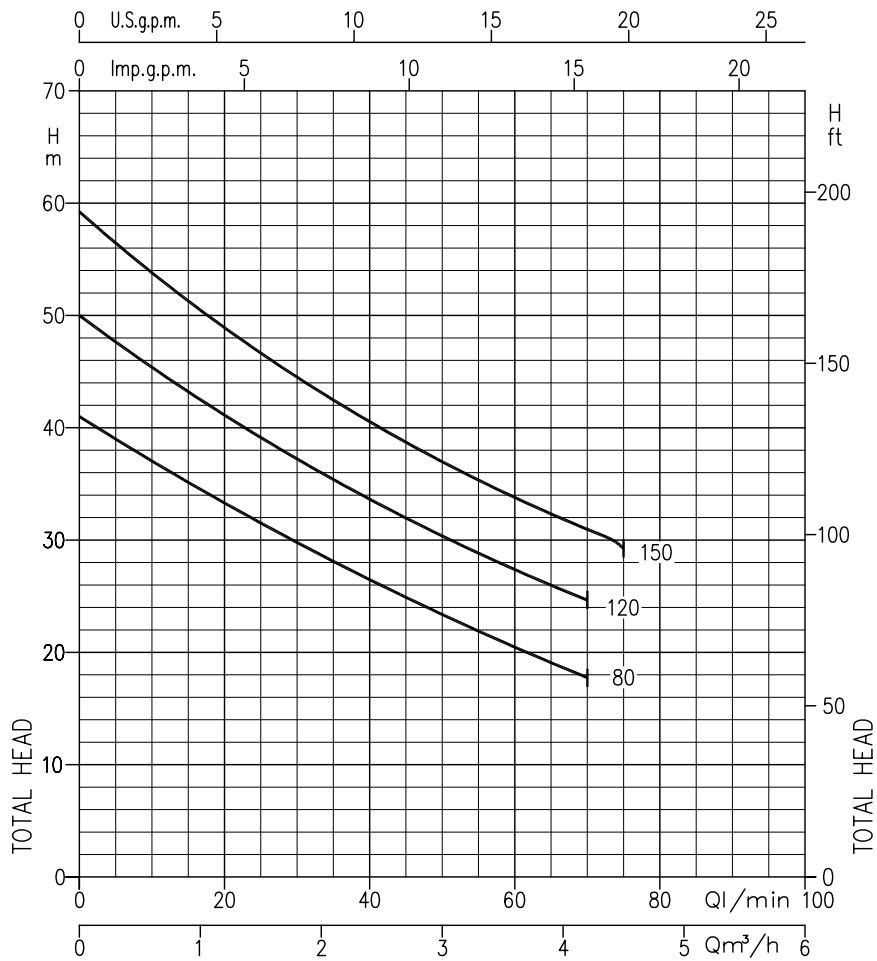

### Curve specifications

The specifications below qualify the curves shown on the following pages.

Tolerances according to ISO 9906 Annex A

The curves refer to effective speed of asynchronous motors at 50 Hz

Measurements were carried out with clean water at 20°C of temperature and with a kinematic viscosity of  $\nu = 1 \text{ mm}^2/\text{s}$  (1 cSt)

In order to avoid the risk of over-heating, the pumps should not be used at a flow rate below 10% of best efficiency point.

Symbols explanation:

Q = volume flow rate

H = total head

### TYPE KEY

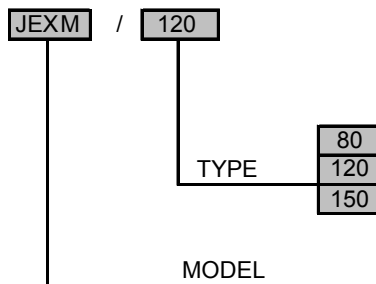

Type pumps Single Phase V 230	Power		Q=Capacity						
	kW	HP	l/min 20	30	40	50	60	70	75
			m³/h 1.2	1,8	2,4	3	3,6	4,2	4,5
JEXM 80	0,6	0,8	33	29	26,5	23,5	20,5	18	-
JEXM 120	0,88	1,2	41	37	34	30,5	27,5	24,5	-
JEXM 150	1,1	1,5	49	44,5	40,5	37	34	31	29,5

JEXM 80 (0.6 kW)

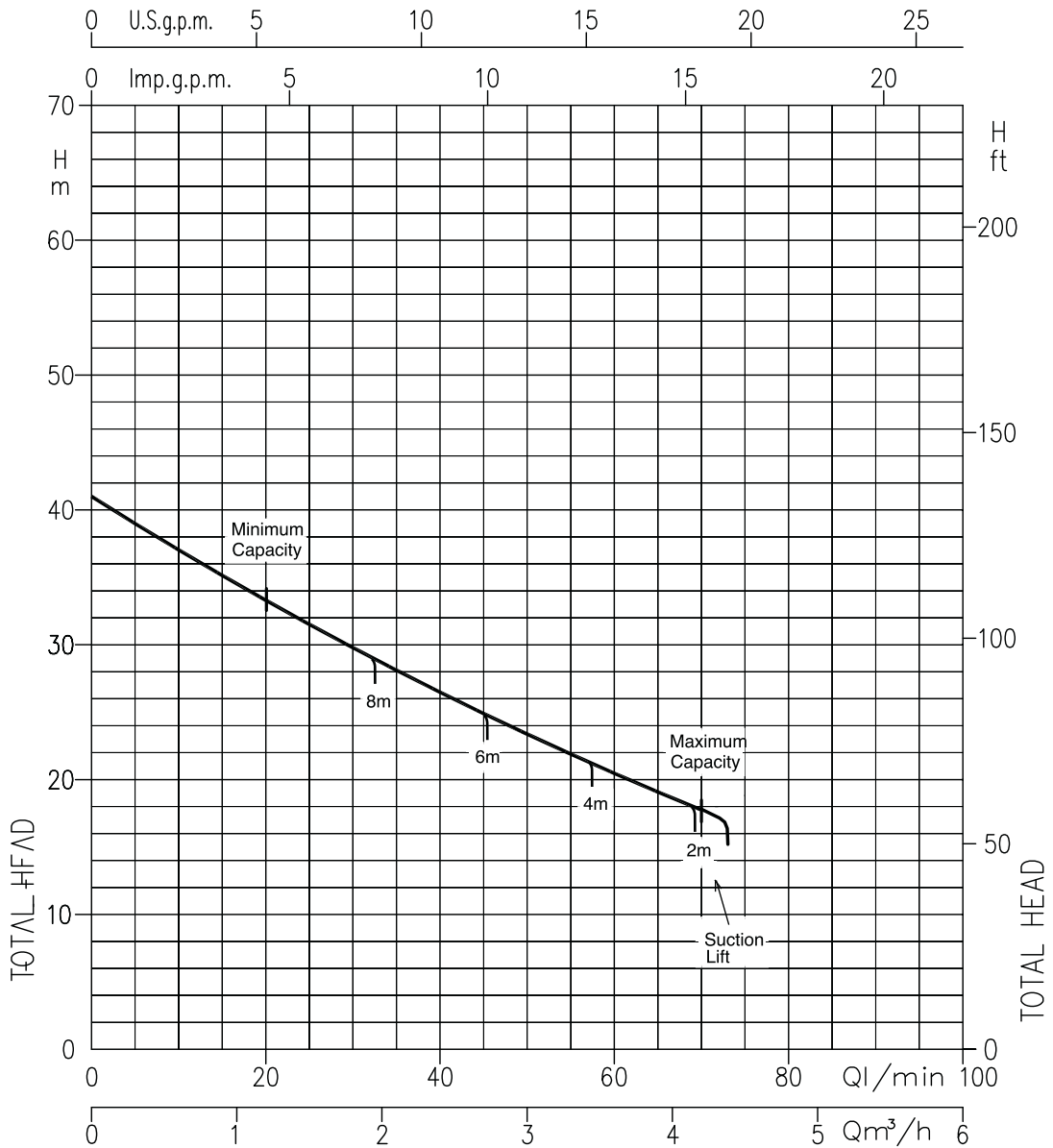

Impeller diameter = 132 mm  
Applicable standard of test: ISO 9906 – Annex A

JEXM 120 (0.88 kW)

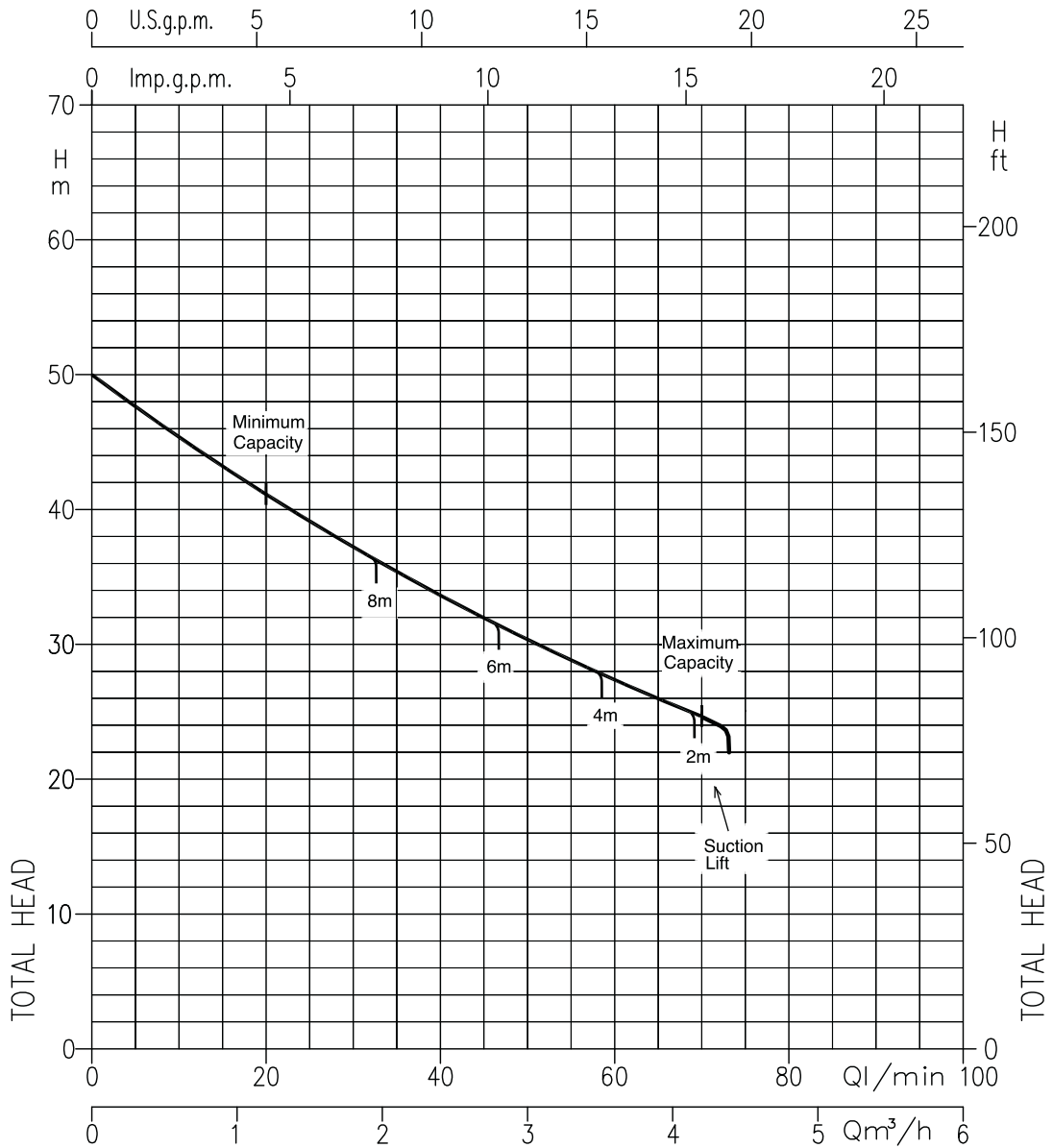

Impeller diameter = 141 mm  
Applicable standard of test: ISO 9906 – Annex A



**JEXM150 (1.1 kW)**

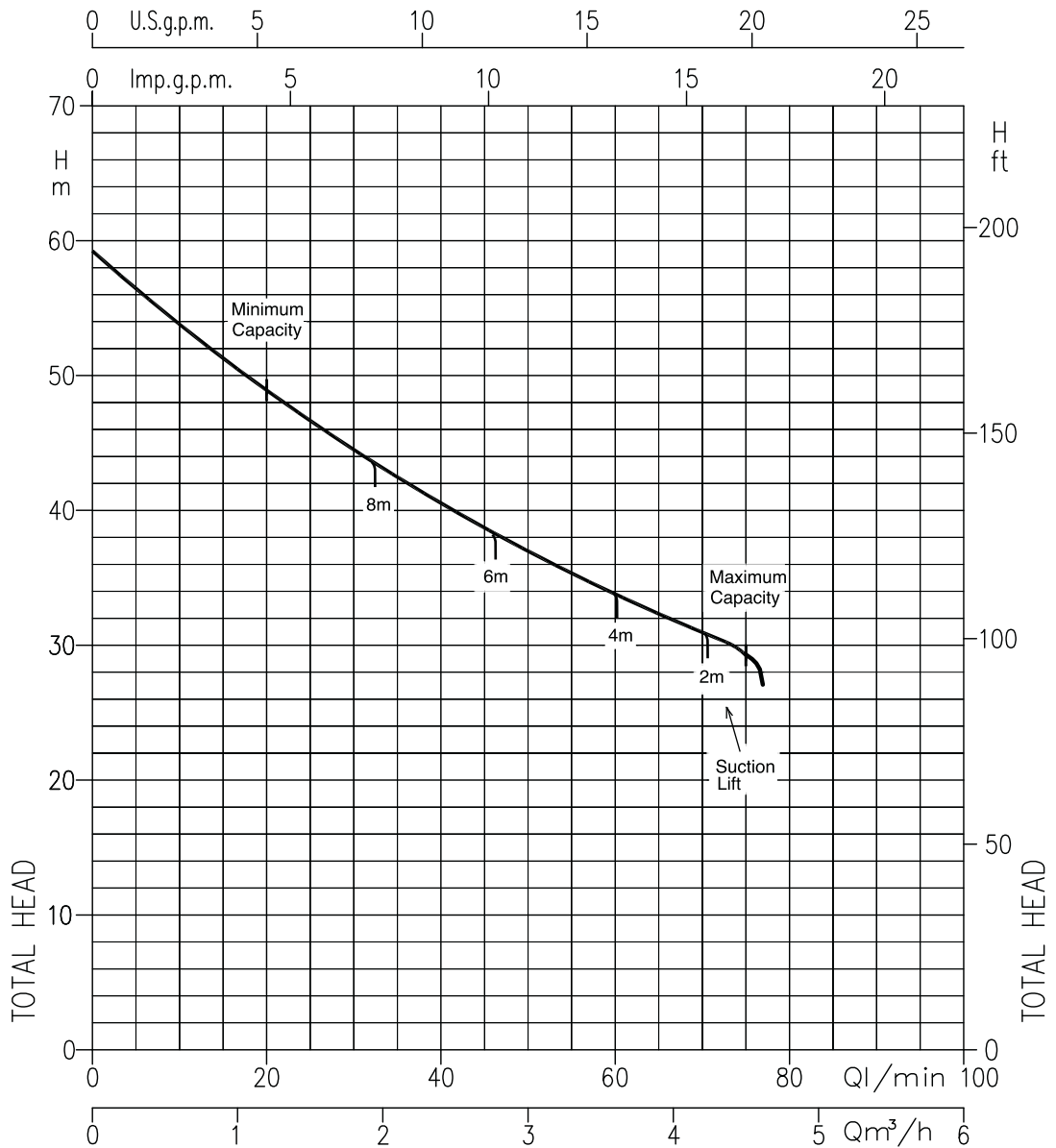

Impeller diameter = 141 mm  
 Applicable standard of test: ISO 9906 – Annex A

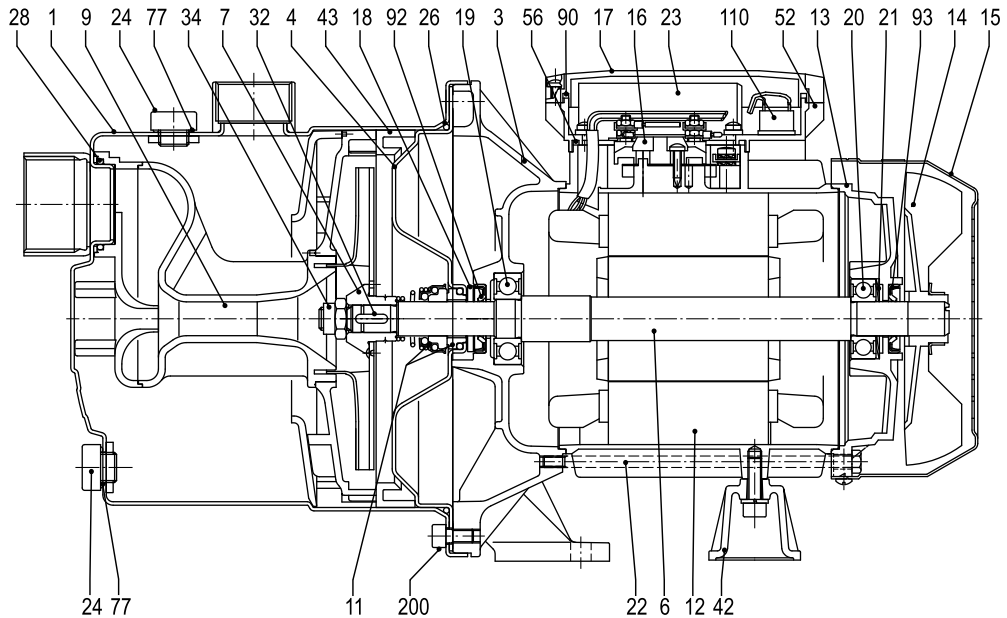

No.	PART NAME	MATERIAL	QTY	No.	PART NAME	MATERIAL	QTY
1	Casing	AISI 304 Stainless Steel	1	22	Tie rod	Fe 420 Zincate	4
3	Motor bracket	Aluminium	1	23	Capacitor	-	1
4	Casing cover	AISI 304 Stainless Steel	1	24	Priming/Drain plug	PA	2
6	Shaft with rotor	AISI 303 S/Steel <small>(Part in contact with liquid)</small>	1	26	O-ring	NBR	1
7	Impeller	AISI 304 Stainless Steel	1	28	O-ring	NBR	1
9	Diffuser Venturi tube	PPE + PS glass fibre reinforced	1	32	Impeller Key	AISI 304 Stainless Steel	1
11	Mechanical seal	Carbon/Ceramic/NBR	1	34	Impeller Nut	AISI 304 Stainless Steel	1
12	Motor frame with stator	-	1	42	Motor Support	Aluminium	1
13	Motor cover	Aluminium	1	43	Space diffuser	PPE + PS glass fibre reinforced	1
14	Fan	PA	1	52	Terminal Box	ABS	1
15	Fan cover	Fe P04 Zincate	1	56	Box gasket	NBR	1
16	Terminal block	-	1	77	O-ring	NBR	2
17	Terminal box cover	ABS	1	90	Cover Gasket	NBR	1
18	Splash ring	NBR	1	92	Lip Seal	-	1
19	Pump side ball bearing	-	1	93	Lip Seal	-	1
20	Fan side ball bearing	-	1	110	Motor protector	- <small>(Only for JEXM 150)</small>	1
21	Adjusting ring	Steel C70	1	200	Screw	Stainless steel A2 UNI7323	8

## MECHANICAL SEAL

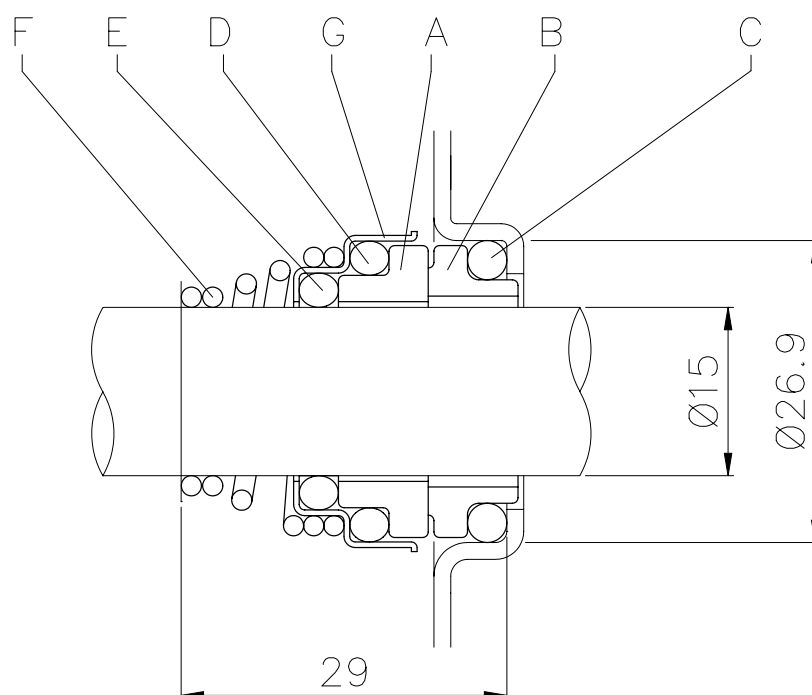

REF	PART NAME	MATERIAL
A	Rotary seal ring	Ceramic
B	Stationary seal ring	Carbon graphite
C	O Ring	NBR
D	O Ring	NBR
E	O Ring	NBR
F	Self driving spring	AISI 316
G	Frame	AISI 304

DIAGRAM AND ELECTRIC CONNECTIONS

SINGLE PHASE MOTOR

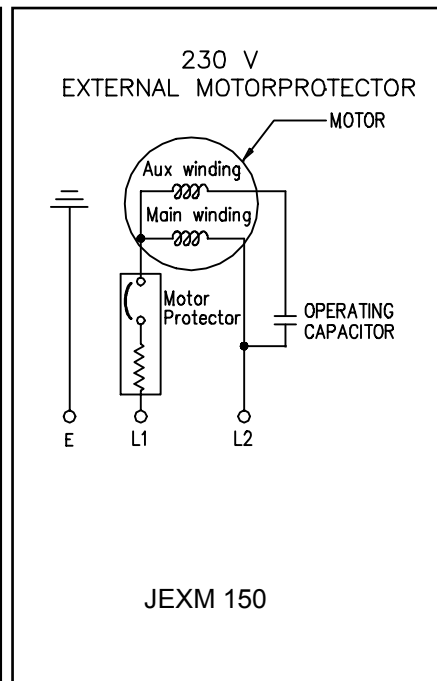
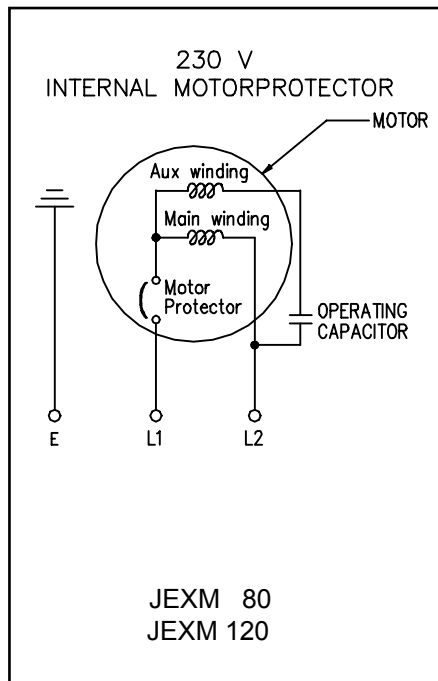
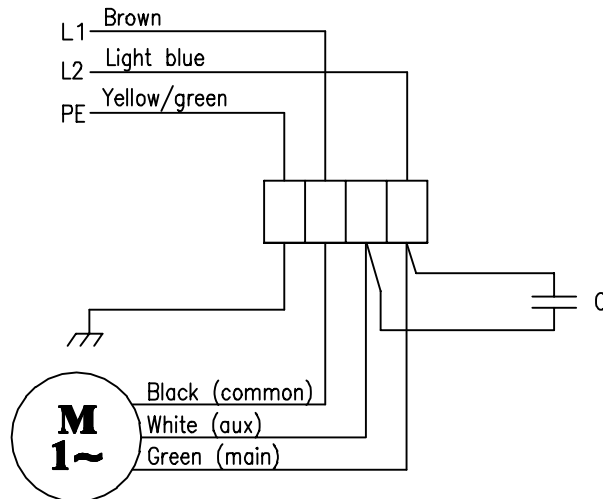

DIMENSIONS

50Hz

V22

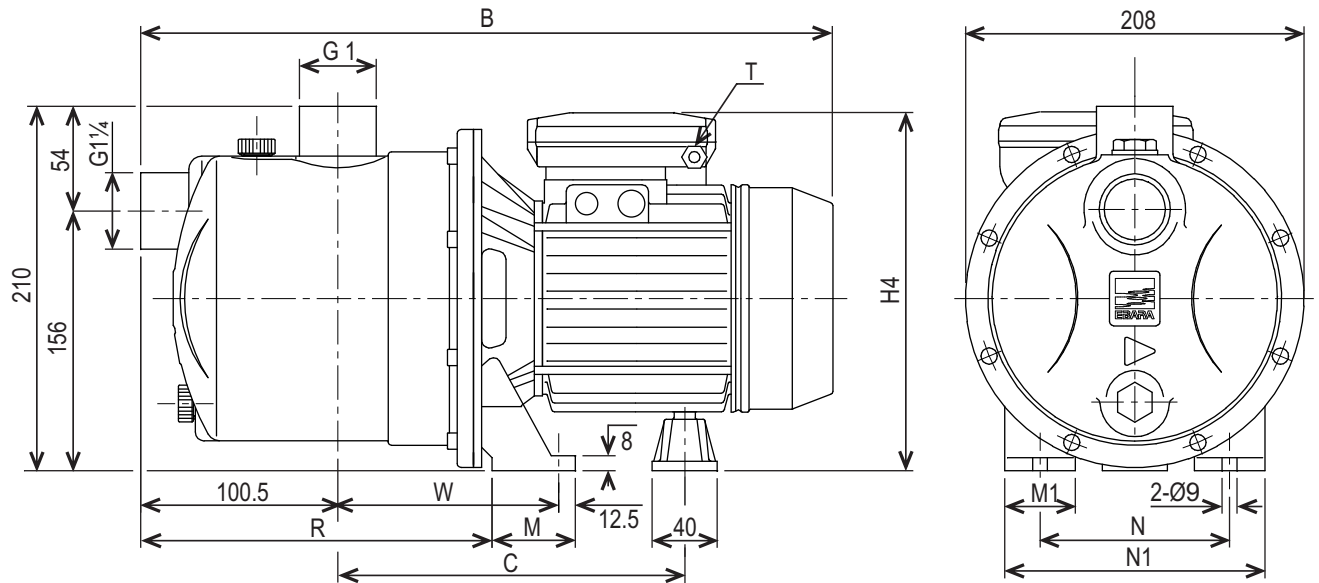

Model	Dimensions (mm)									
	B	C	H4	M	M1	N	N1	R	T	W
JEXM 080	417	230	215	50	38	120	160	206	PG11	143
JEXM 120	417	230	215	50	38	120	160	206	PG11	143
JEXM 150	445	250	240	55	40	140	180	203.5	PG13.5	145.5

PACKING AND WEIGHT

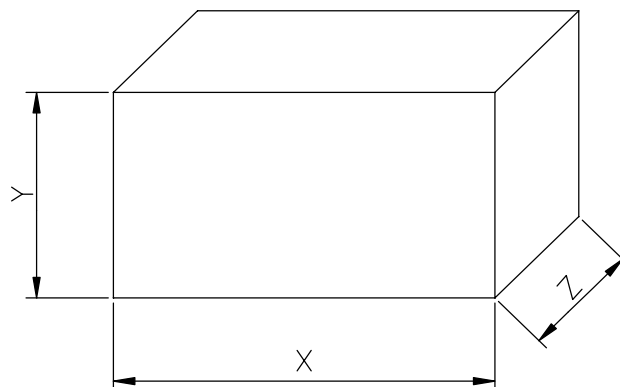

Type pumps Single Phase	PACKING [mm]			WEIGHT [kg]
	X	Y	Z	
JEXM 80	222	265	462	10.3
JEXM 120	222	265	462	11.5
JEXM 150	222	265	462	14.1

## TECHNICAL DATA - MOTOR AND BEARINGS

50Hz

V22

Type pumps Single Phase 230 V 50 Hz	kW	HP	Capacitor		Input [kW]	Full load current [A]	Locked rotor current [A]
			μF	Vc			
JEXM 80	0.6	0.8	16	450	1.05	4.7	16.1
JEXM 120	0.88	1.2	20	450	1.39	6.7	22.7
JEXM 150	1.1	1.5	31.5	450	1.70	7.6	32.5

Type pumps	Ball Bearing	
	Pump side	Fan side
JEXM 80	6203 2DW C3	6202 2DW C3
JEXM 120	6203 ZZ C3	6202 ZZ C3
JEXM 150	6204 ZZ C3	6203 ZZ C3



Install a foot valve or check valve in the suction pipe.  
Support the suction and delivery pipe to prevent damage to the pump casing.

